

fanzarelli

ELECTRIC MOTO 

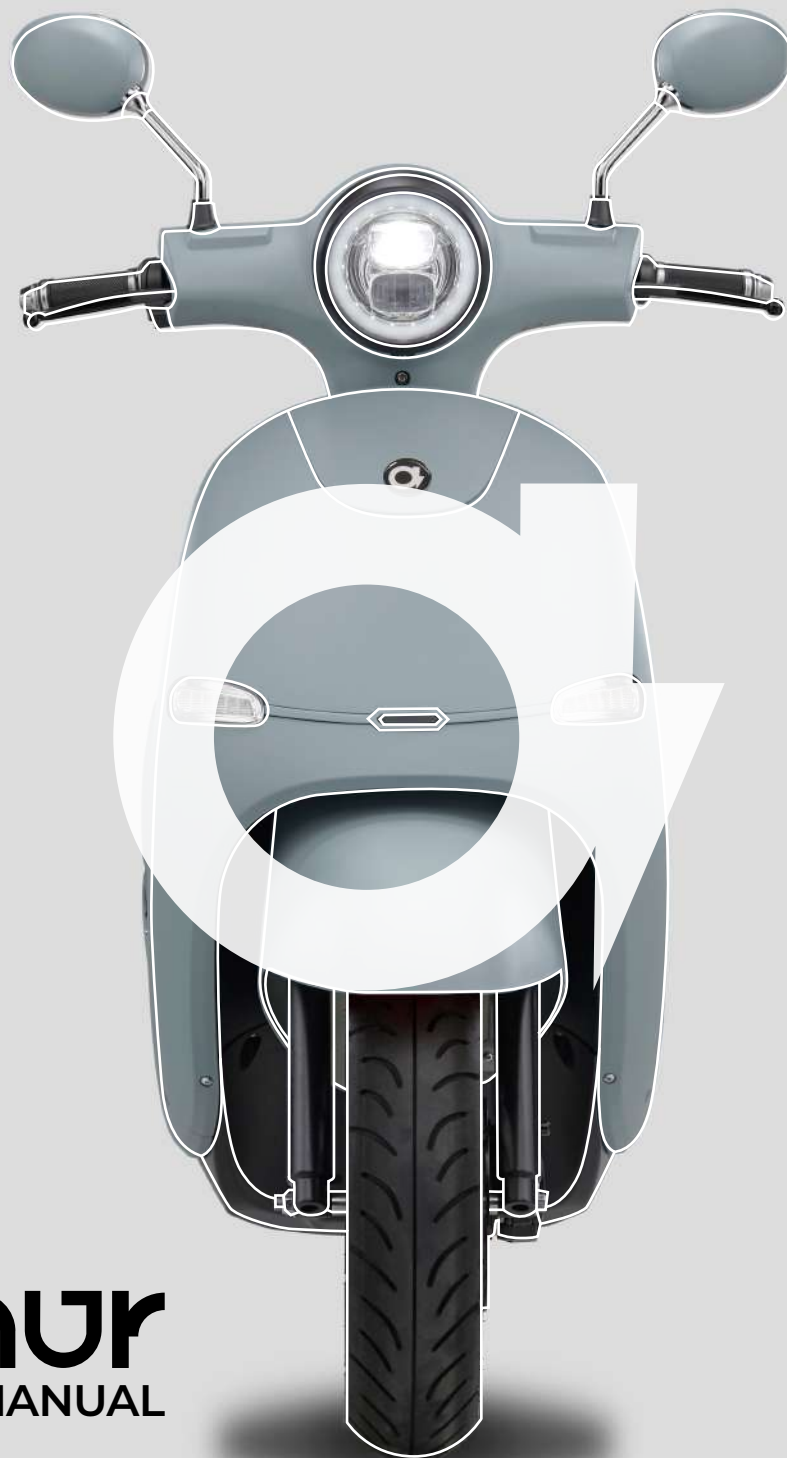

arthur
OWNER'S MANUAL

Welcome to

FONZ

Welcome to the Fonz community - you've just taken a positive step in reducing your carbon footprint!

Arthur is the perfect commuter vehicle. It allows you to easily negotiate traffic and park almost anywhere. The smooth and responsive digitally-controlled powertrain can be optimised to suit your riding style. Your dynamic ride customisations can include regenerative braking to improve efficiency and power configuration.

Not unlike your laptop or mobile phone, recharging Arthur is suited to the evening so you can probably benefit from off-peak rates.

Now it's time to get to know your electric ride!

What is Lithium Ion?

The PowerPack in your Arthur utilises high quality lithium technology; the forefront of rechargeable cell technology with superior reliability, recharging time and power to weight ratio.

The PowerPack does not develop "charge memory" so you can recharge as frequently as it is convenient to do so.

Lithium Ion is an environmentally sustainable technology and does not use heavy metals like mercury or cadmium found in other batteries.

arthur

OWNER'S MANUAL

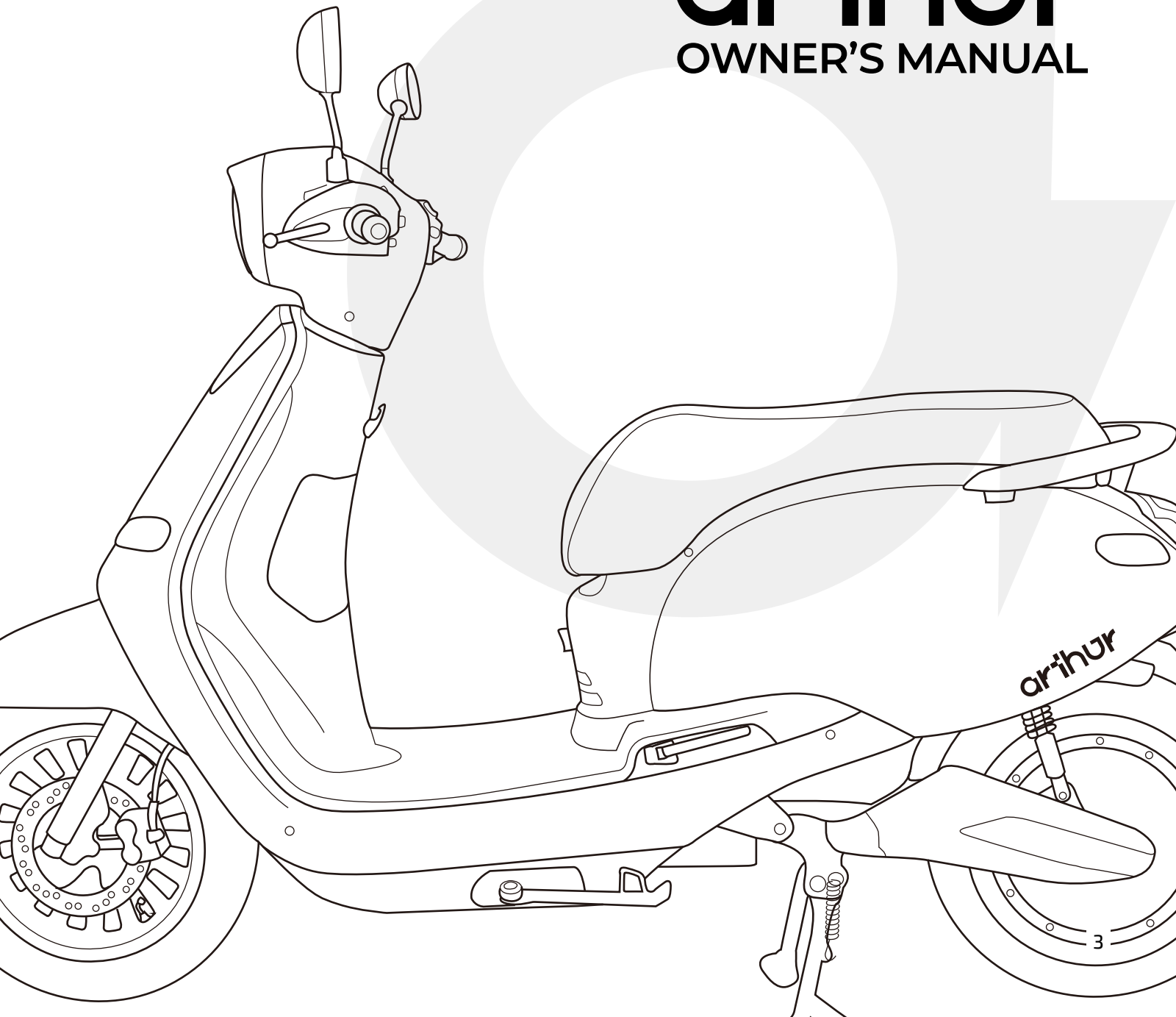

Important Notice

Arthur is rated to carry the operator and up to one passenger. Combined weight of rider, passenger, accessories and cargo must never exceed the maximum rated load capacity of 150kg. Minimising load will improve performance.

Arthur is designed to travel on sealed roads only. Personal injury or mechanical damage may result if you do not operate the vehicle in accordance with the guidelines of this document.



This symbol indicates that severe personal injury or damage to equipment may result if instructions are not followed.

Unless specified, 'Arthur 1' refers to the LA Fonzarelli 100 moped category, Arthur 2 and Arthur 3 refer to LC Fonzarelli 125 motorcycle category.

Read this Owners Manual carefully, and retain it for future reference.

Running in



Brakes & Tyres

Ride slowly and apply brakes gently to run in tyres and brake pads during the first 100km. We recommend keeping speed below 45km/h during the run in period.

PowerPack

Allow 5 to 8 charge cycles for optimal PowerPack performance as the system learns your PowerPack cells.

During the first 200KM do not to drop your PowerPack below 40%.

All information in this Owners Manual is correct at the time of publication. Fonzarelli Bikes reserves the right to make changes at any time without incurring obligation. © Fonzarelli Bikes 2020.

Content

Safe Riding	6	Reverse, Regeneration	23
Equipment	7	Reverse & Parking	
Right side		Regeneration braking	
Left side		Dynamic regeneration	
Handlebars	9	Storage & load	24
Instruments	10	Pillion passenger	
Ignition	11	Accessories	
PowerPack	12	Specification	26
Equipment		Maintenance	27
Installation		Cleaning	
Charger	15	Tyres	
Charging the PowerPack		Brakes	
Stands	17	Maintenance schedule	
Kick stand		Electronics	30
Centre stand		PowerPack storage	
Vehicle identification	19	Operating temperature	
VIN location		Long-term storage	
Motor (engine) number		Range & Performance	31
Compliance plate		Warranty	32
Riding	21		
Pre-ride inspection			
Starting procedure			
Review safety before you ride			
Braking			

Safe Riding

Conduct a pre-ride check before you turn on the vehicle. This will prevent any accidental damage to equipment.

Safe riding rules

- ⚡ Obey all road regulations, and ride in a manner befitting road conditions
- ⚡ Keep your hands and feet fixed firmly to the vehicle at all times when riding
- ⚡ Always take extra caution at intersections, in high traffic situations, and when lane filtering
- ⚡ A compliant motorcycle helmet must be worn at all times when riding
- ⚡ Wearing a rider jacket, gloves and boots is strongly advised
- ⚡ Ensure that you hold the required rider licence for your state
- ⚡ Never lend your vehicle to an inexperienced rider
- ⚡ Never ride in another driver's "blind spot"
- ⚡ Above all, ride to live; employ common sense in all traffic situations

Further riding rules and tips can be found on the website of your local transport authority.

Running in

See page 4 for information about running in your Arthur.

Equipment

List of parts - **R**

- | | |
|-----------------------|--------------------------|
| 1. Rear view mirrors | 9. Rear reflector |
| 2. Headlamp | 10. Rear indicator |
| 3. Front brake lever | 11. Pillion dink grips |
| 4. Front indicator | 12. Pillion |
| 5. Front suspension | 13. Saddle |
| 6. Centre stand | 14. External Charge Port |
| 7. Rear disc brake | 15. Ignition |
| 8. Rear brake caliper | 16. Throttle |

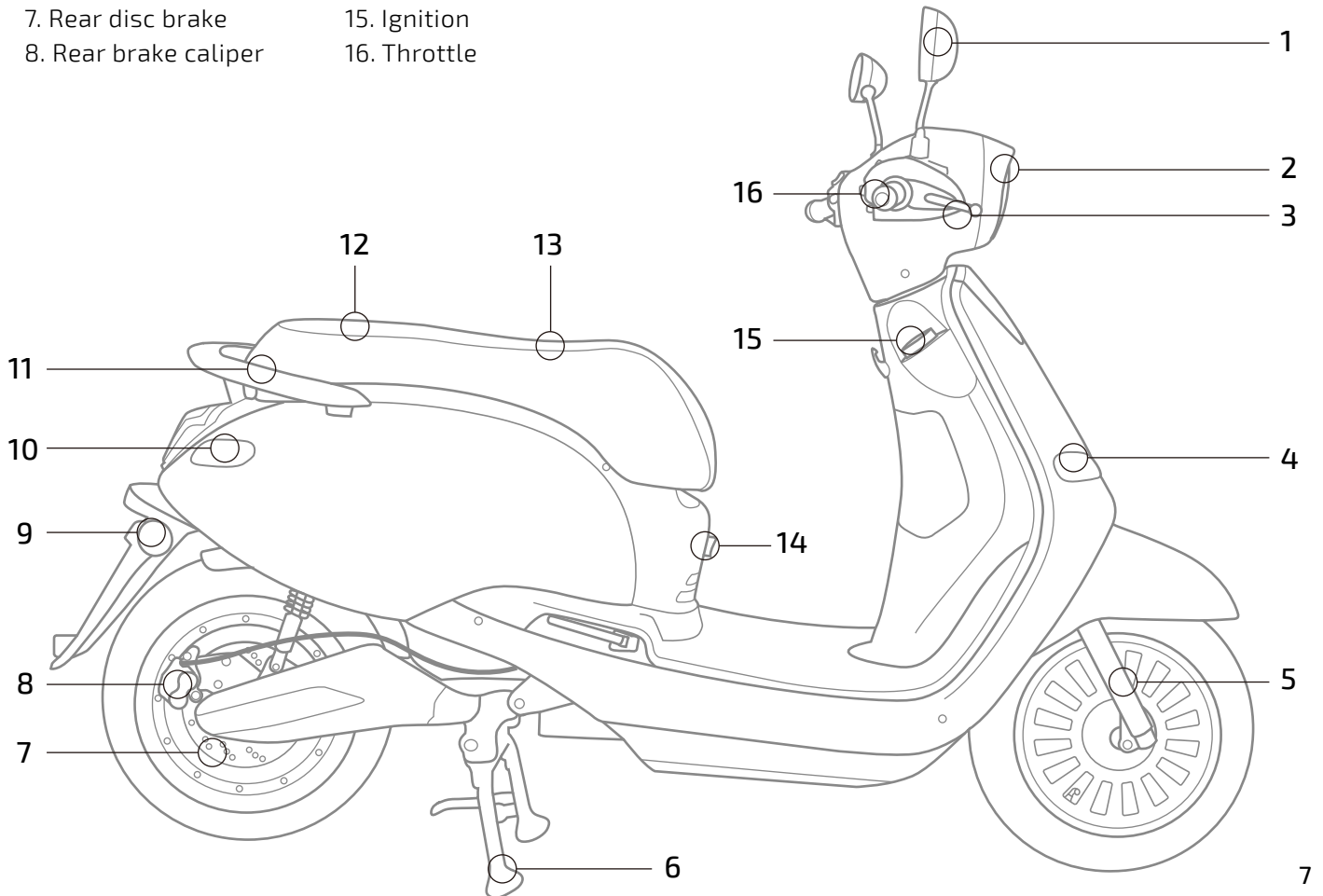

The Kit

List of parts - **L**

- | | |
|---|-------------------------|
| 16. Under saddle storage
powerpack compartment | 22. Side stand |
| 17. Tail light | 23. Front disc brake |
| 18. Rear indicator | 24. Front brake caliper |
| 19. Rear suspension | 25. Front indicator |
| 20. Motor number | 26. Rear brake lever |
| 21. Pillion foot pegs | 27. Bag hook |
| | 28. Storage Compartment |

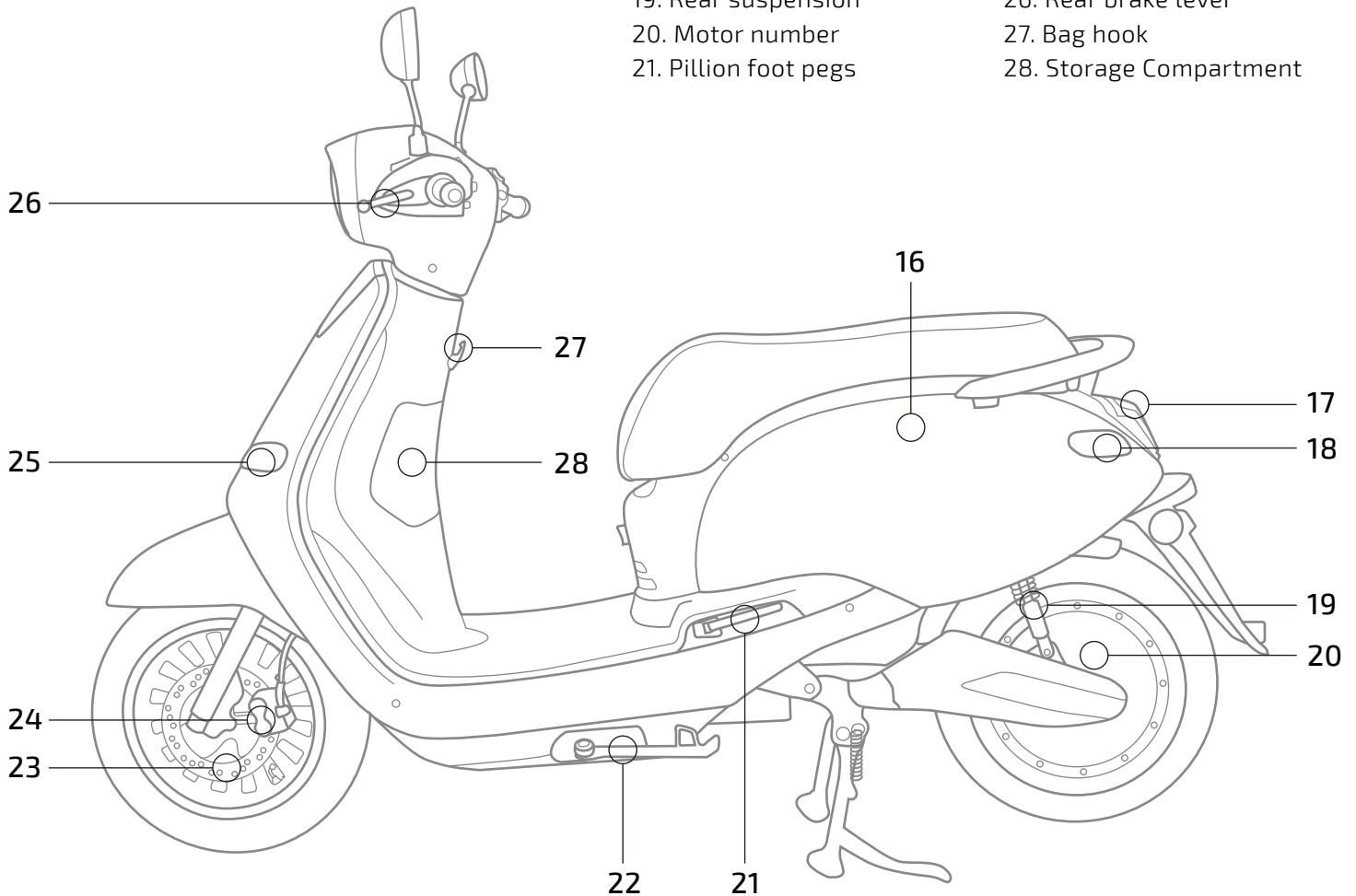

Handlebars

1. High beam/Low beam
2. Indicator switch
3. Horn
4. Hazard switch light
5. Kill switch
6. Ready & Reverse
7. Power modes (varies by model)

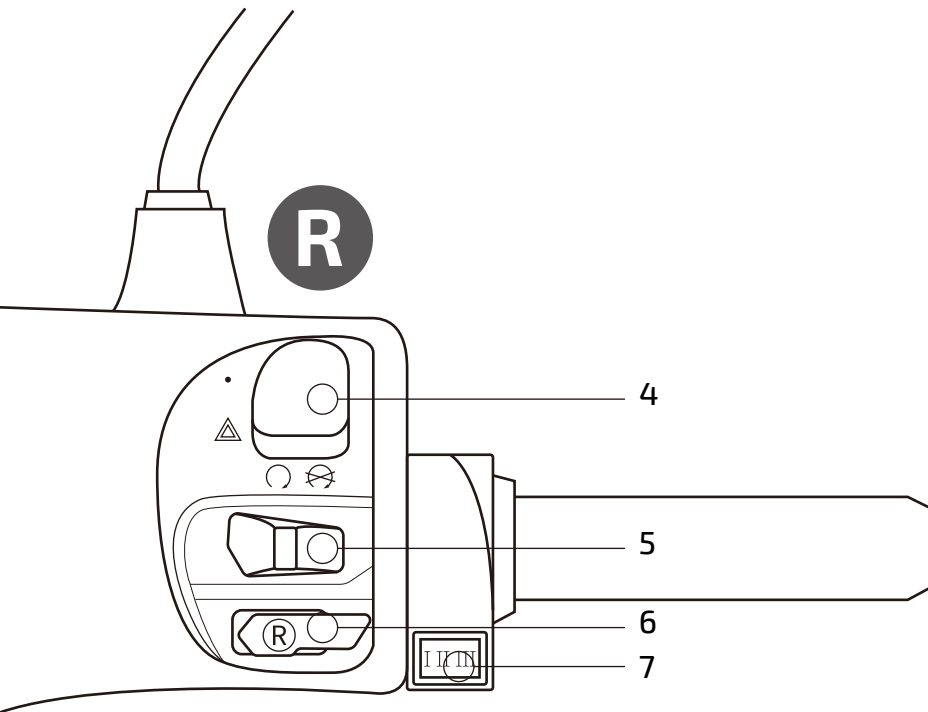
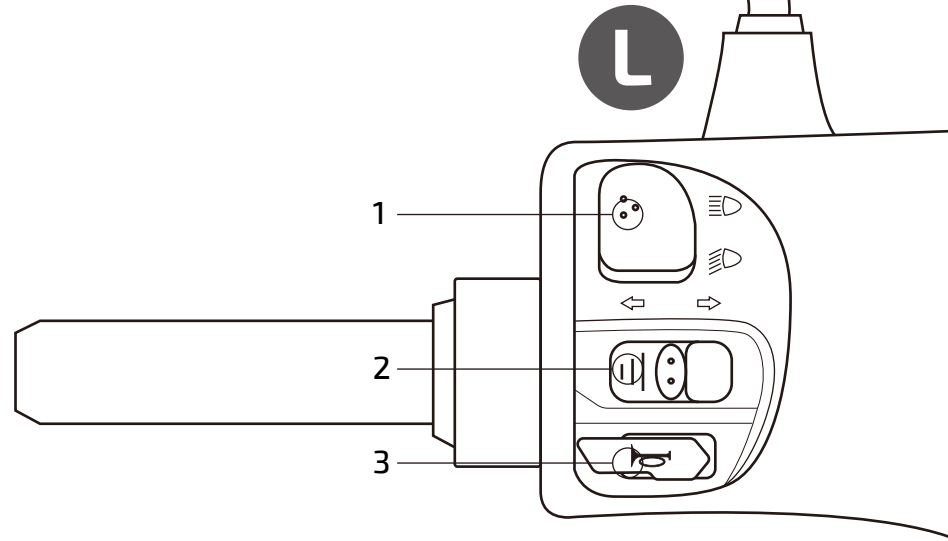

Instruments

1. PowerPack percentage
2. Indicator on signal
3. High beam signal
4. Power mode
5. Speed
- 6a. Odometer, 3 seconds following power on
- 6b. Estimated mileage (kilometres) during ride mode
7. Powerpack SOC %

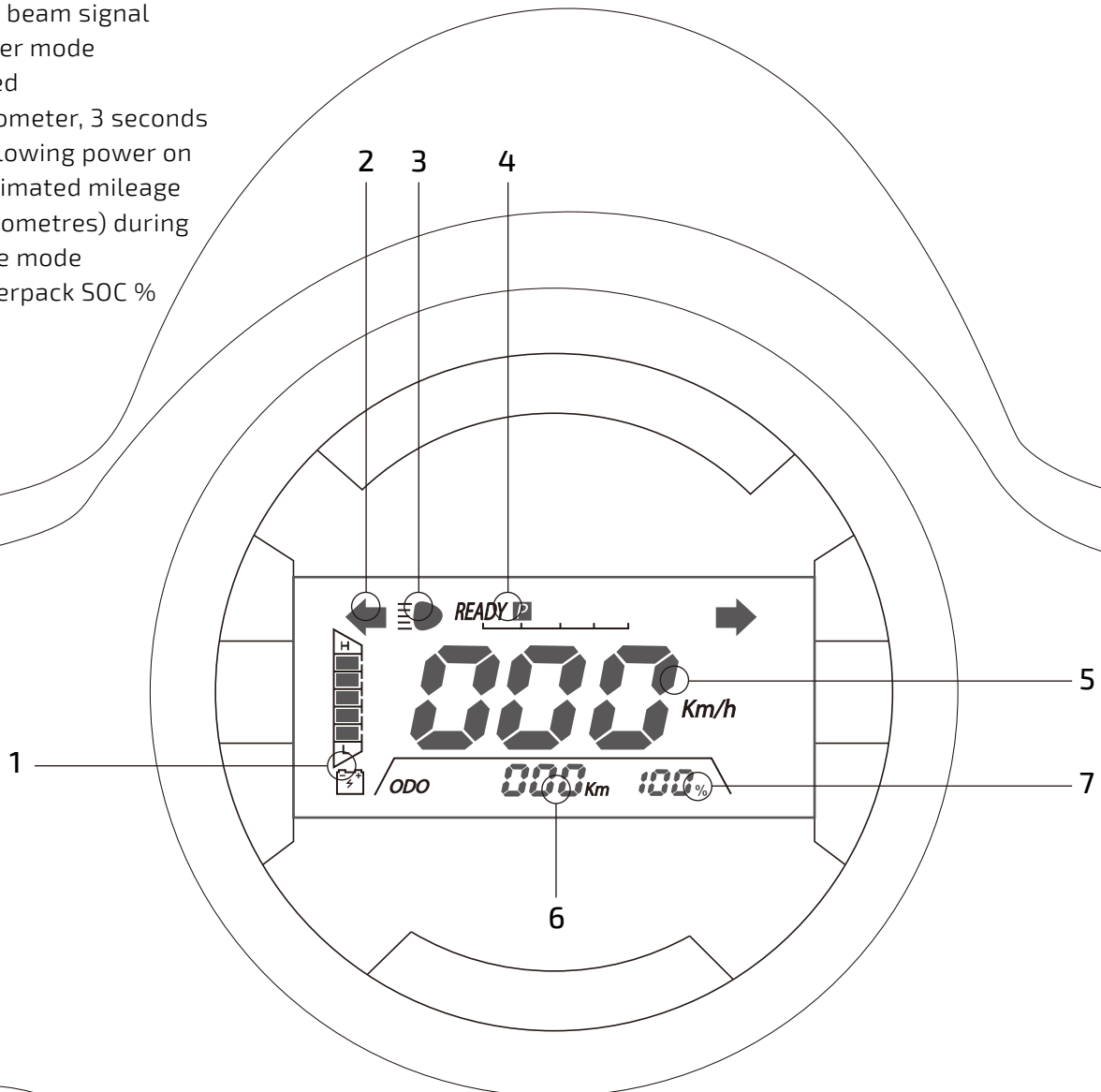

Ignition

Power On / Off

1. Insert key
2. Turn key clockwise to ON position 
3. Press 'Ready' to activate ride mode (p.9, item6)

Saddle Release

1. Insert key 
2. Gently turn the key slightly further than the OFF position to disengage saddle latch

TIP: do not push down on the key or saddle cannot release.

Steering Lock

As an anti-theft precaution, Arthur is fitted with a steering lock after parking.

1. Parking
2. Ensure the handlebars are in the full left position
3. From the OFF position, push down on the key, and rotate anticlockwise to the STEERING LOCK position  •
4. If the steering lock does not immediately engage, gently rock the handlebars a few degrees left to right while turning the key

Disengaging Steering Lock

1. Handlebars will be in the full left position
2. From the STEERING LOCK position, push down on the key, and rotate key clockwise to the OFF position
3. If the steering lock does not immediately disengage, gently rock the handlebars a few degrees left to right while turning the key

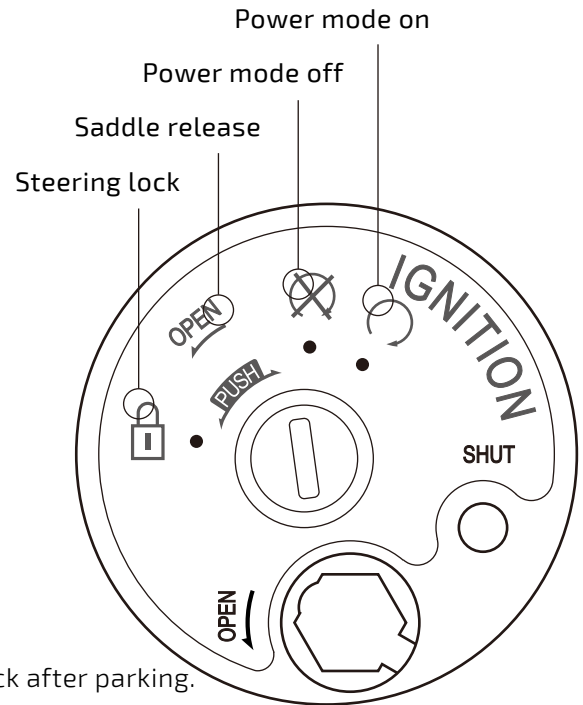

PowerPack

Powerpack cover
Locking mechanism

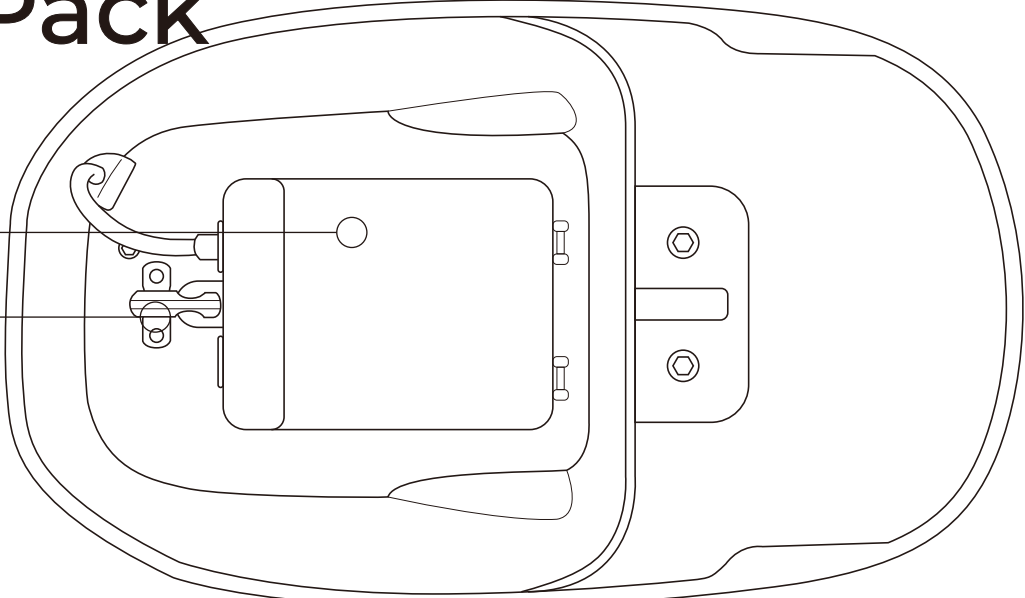

Connector
PowerPack

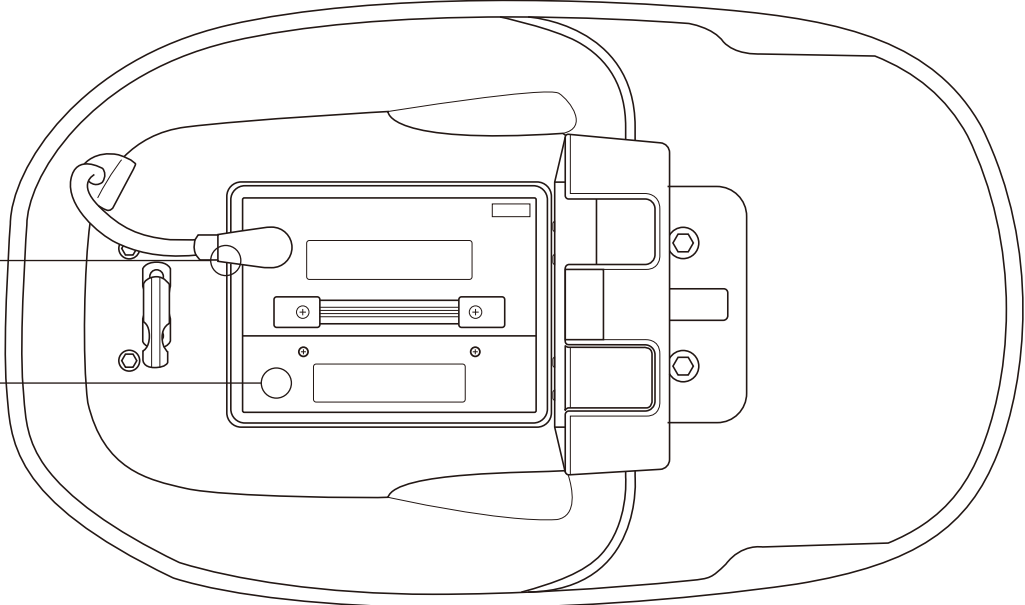

Note: Image depicts Arthur Model 1, 2 Configuration. Layout may vary by model.

PowerPack

PowerPack equipment

- 1. Power connector
- 2. Charge port
- 3. Safety switch
- 4. Charge level

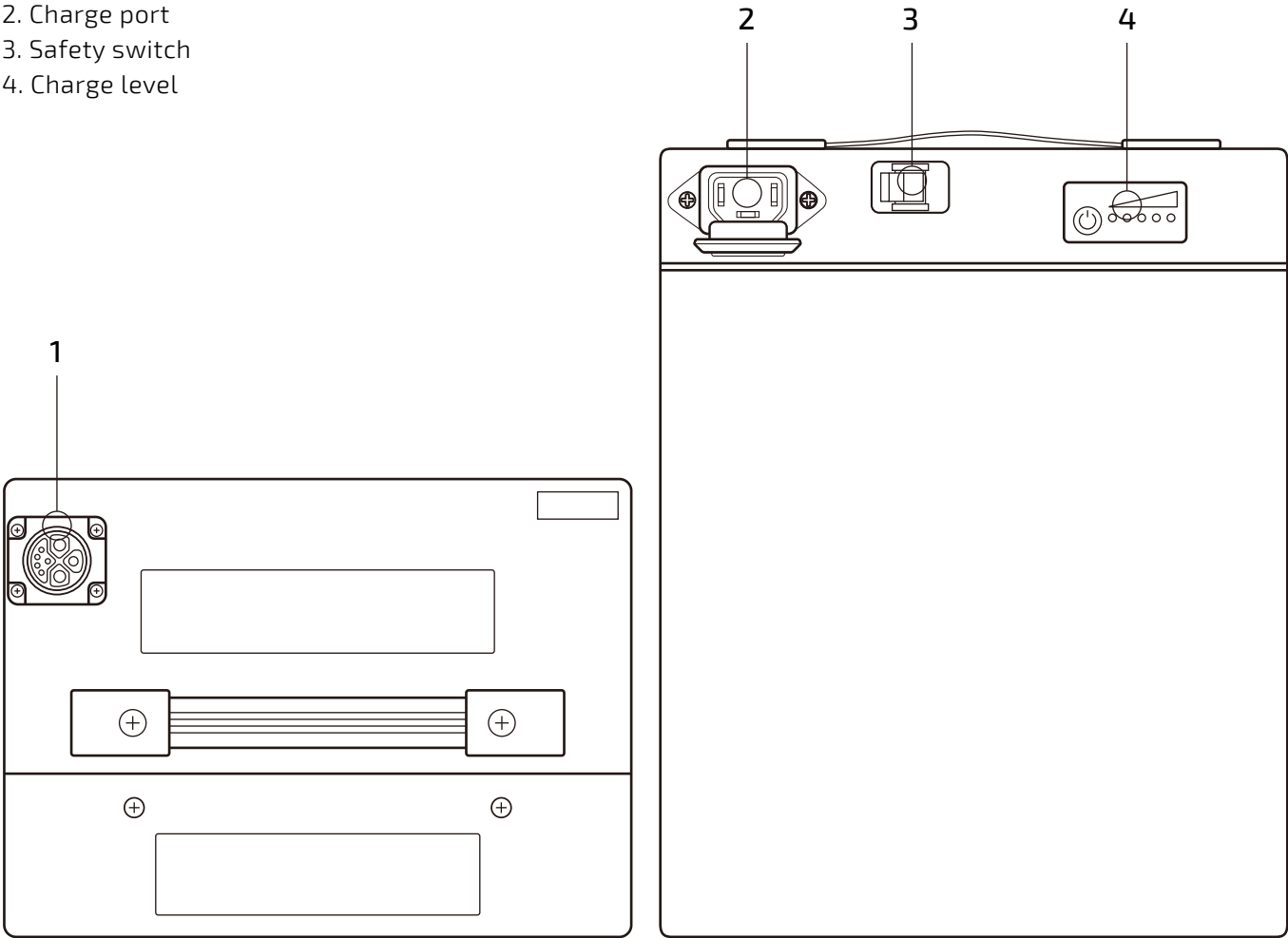

Note: Image depicts Arthur Model 1. Configuration will vary by model variants.

PowerPack

Installation of PowerPack - Model 1 & 2

1. Insert the key, and turn anticlockwise to the saddle latch release position
2. Remove key from ignition
3. Lift the saddle
4. Release PowerPack cover by turning white locking mechanism clockwise
5. Lift PowerPack cover
6. Ensure PowerPack safety switch is set to the OFF position (right, toward the back of the PowerPack and the scooter)
7. Insert the PowerPack into the holding bay
8. Connect power Connector (blue colour).
9. Set safety switch to ON position (left, toward front of the PowerPack and scooter)
10. Close PowerPack cover
11. Return locking mechanism anticlockwise to lock cover in place

TIP



For a longer service life, prevent arcing wear and tear on the Power Connector by turning the Safety Switch to OFF position when the Power Connector is being connected / disconnected. You can also minimise sparking by ensuring the ignition is turned to OFF.

Safety Information

- NEVER store the charger outdoors. Always store indoors when not in use.
- NEVER place the output cable, power cord or charger on a wet surface.
- NEVER use the charger with defective power cord and/or damaged wires.
- DO NOT use in extremely humid conditions.
- DO NOT place the charger directly in sun light.
- NEVER use the charger near flammable and explosive areas.
- ALWAYS keep the charger vent 10cm away from other objects & DO NOT cover.
- Unplug charger from AC outlet before attempting any maintenance or cleaning.
- Place the charger in a clean and ventilated environment while charging.
- Plug in and unplug the AC power cord by grasping the plug.
- Do not drag the power cord itself to reduce risk of damaging power cord.

Warning!

You must only use the charger supplied by Fonzarelli Bikes. Do not use aftermarket products with the powerpack.

These techniques will ensure system integrity and precisely control the charging voltage and current. The Powerpack will be fully charged but not overcharged.

Frequent charging will not effect life cycles. From time-to-time ensure discharging calibrate cells to PowerPack management system by charging & discharging 100%-5%.

TIP

Charge your Arthur anywhere. Portable charger may be stowed under the saddle. It must be stored in charger pouch and secured to avoid damage to the charger while riding.

LIMITED WARRANTY

Every charger has been tested before shipping. Please contact customer support immediately if there is any damage to the charger.

The warranty is void if :

Operation instructions are not followed
Warranty period has passed
The damage is caused by improper operation
Damages caused by force majeure

Stands

Kick stand

Use the kick stand when parking the scooter for a short amount of time.

1. Position the scooter on firm level ground. If you park on inclined ground, ensure that the front wheel is pointing up-hill
2. Engage the kill switch
3. Swing the side-stand down, and support the scooter on the side-stand
4. Dismount the scooter, and turn the handlebars fully to the left
5. Turn the key to the OFF position

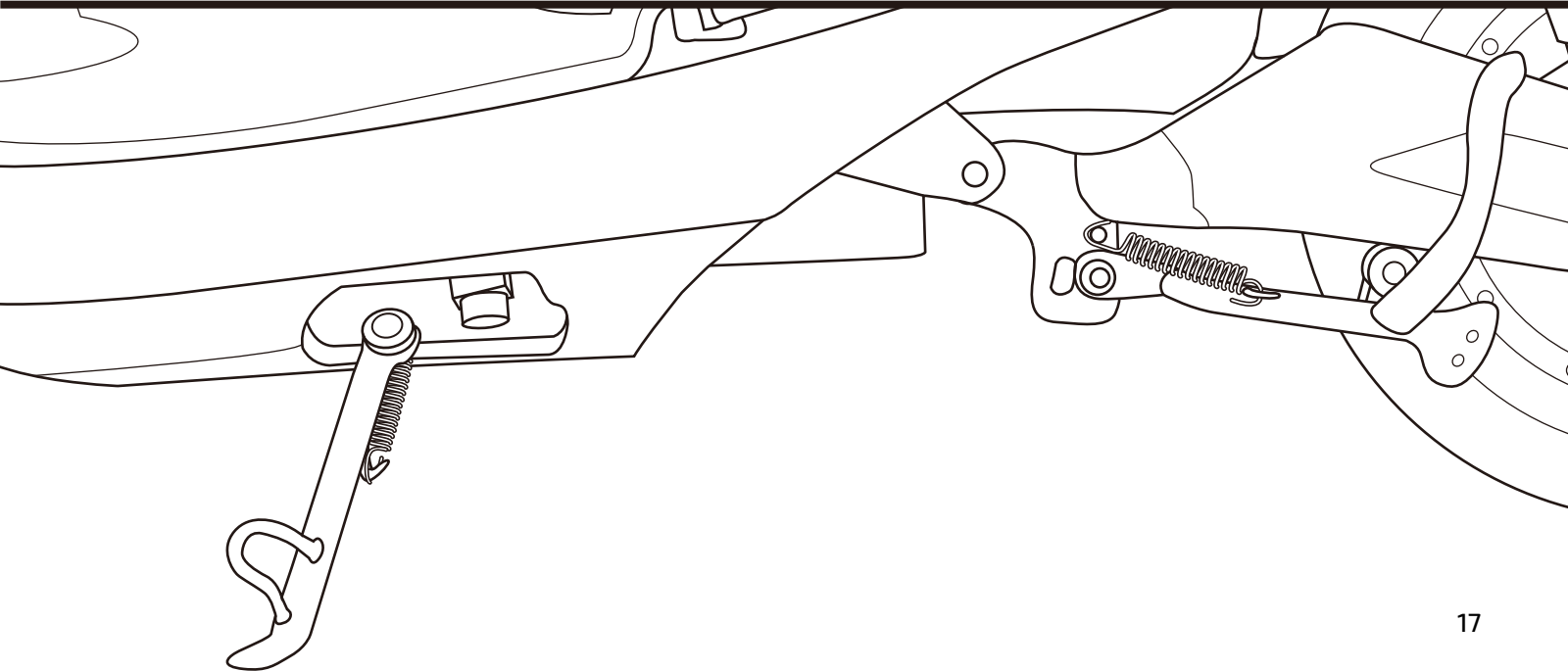

Stands

Centre stand

The centre stand should be employed when parking the scooter for extended periods or when undertaking maintenance.

1. While dismounted, hold the left hand grip with your left hand
2. With your right hand, hold the pillion passenger left hand grip
3. While applying firm pressure to the main stand foot lever, lift the rear of the scooter
4. Ensure the weight is fully supported by the main stand before you release grip of the scooter

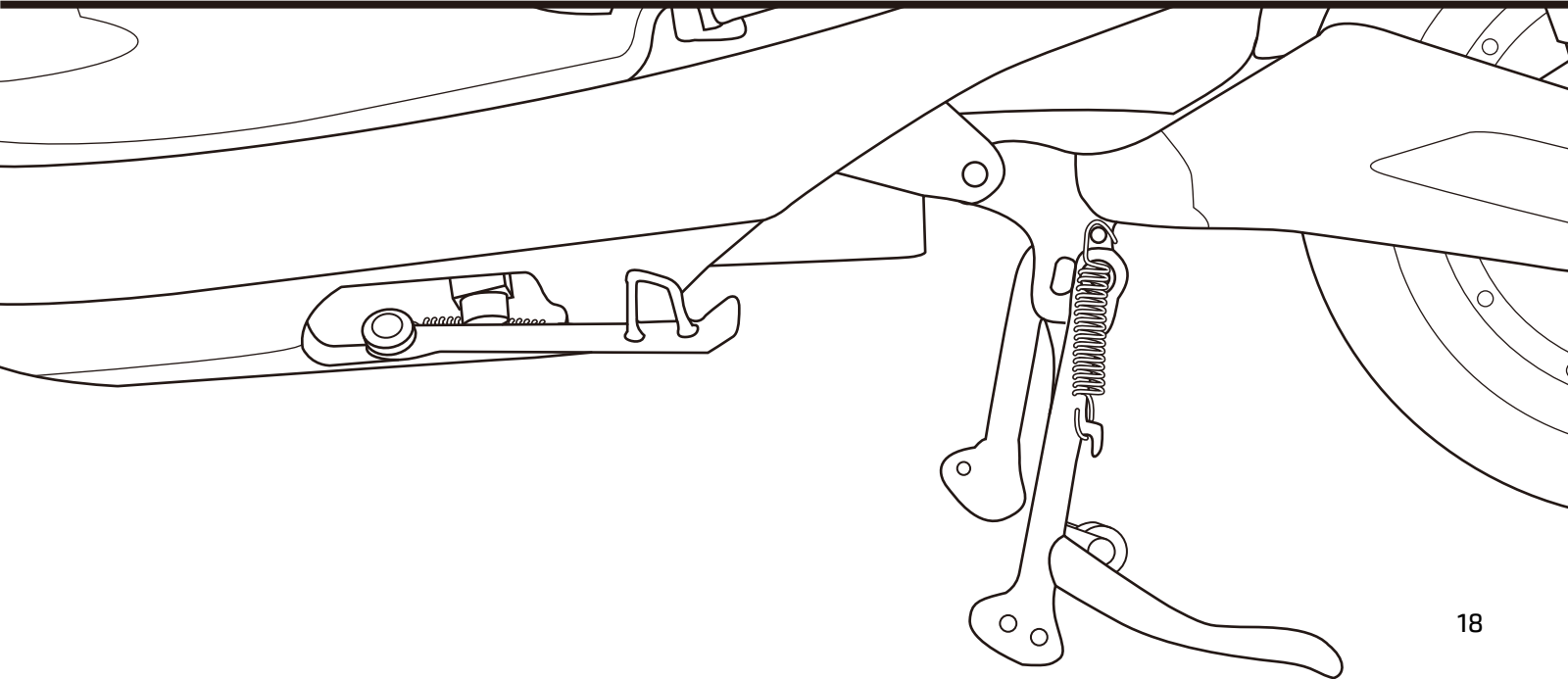

Vehicle Identification

VIN Location
Motor (engine) number

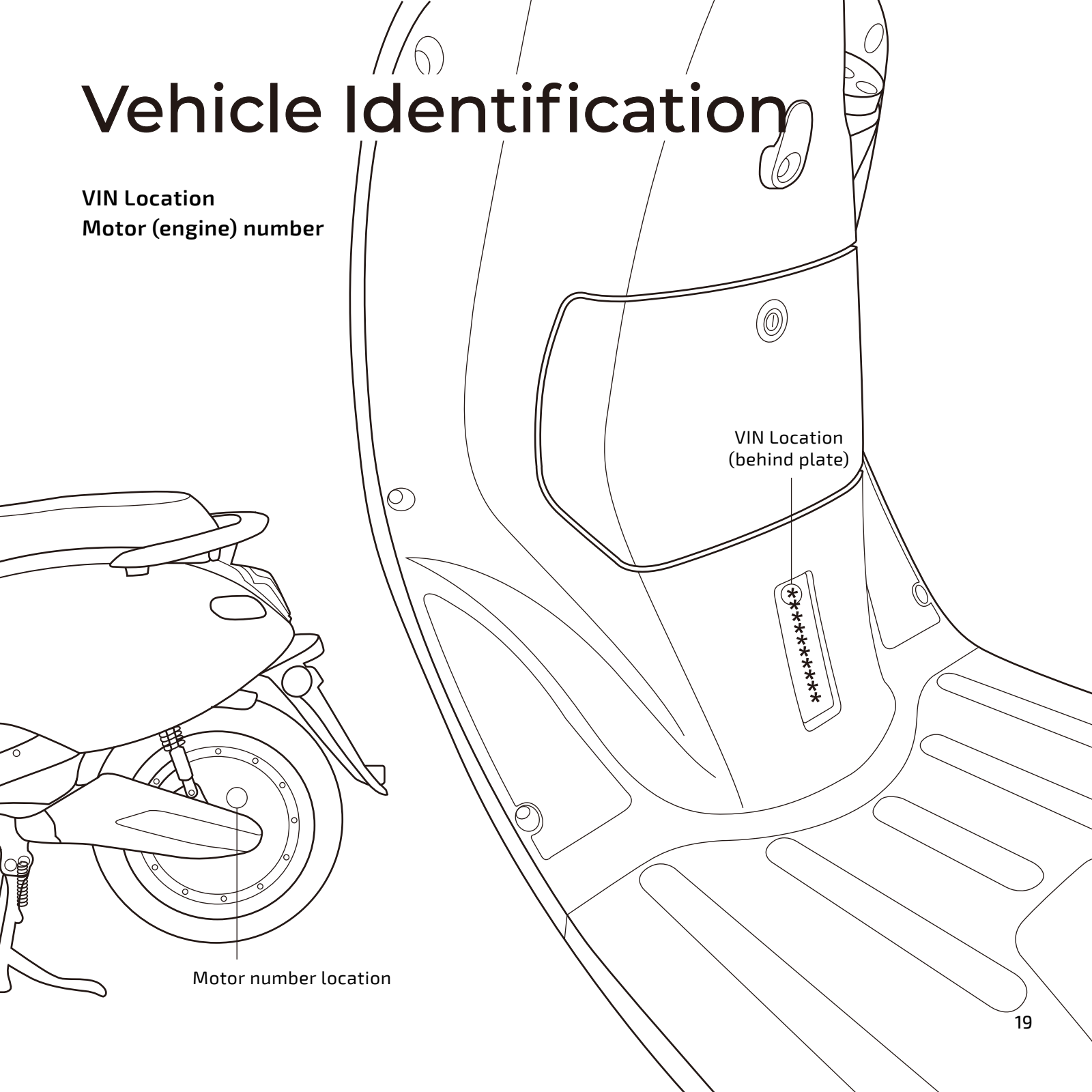

VIN Location
(behind plate)

Motor number location

Vehicle Identification

Compliance plate

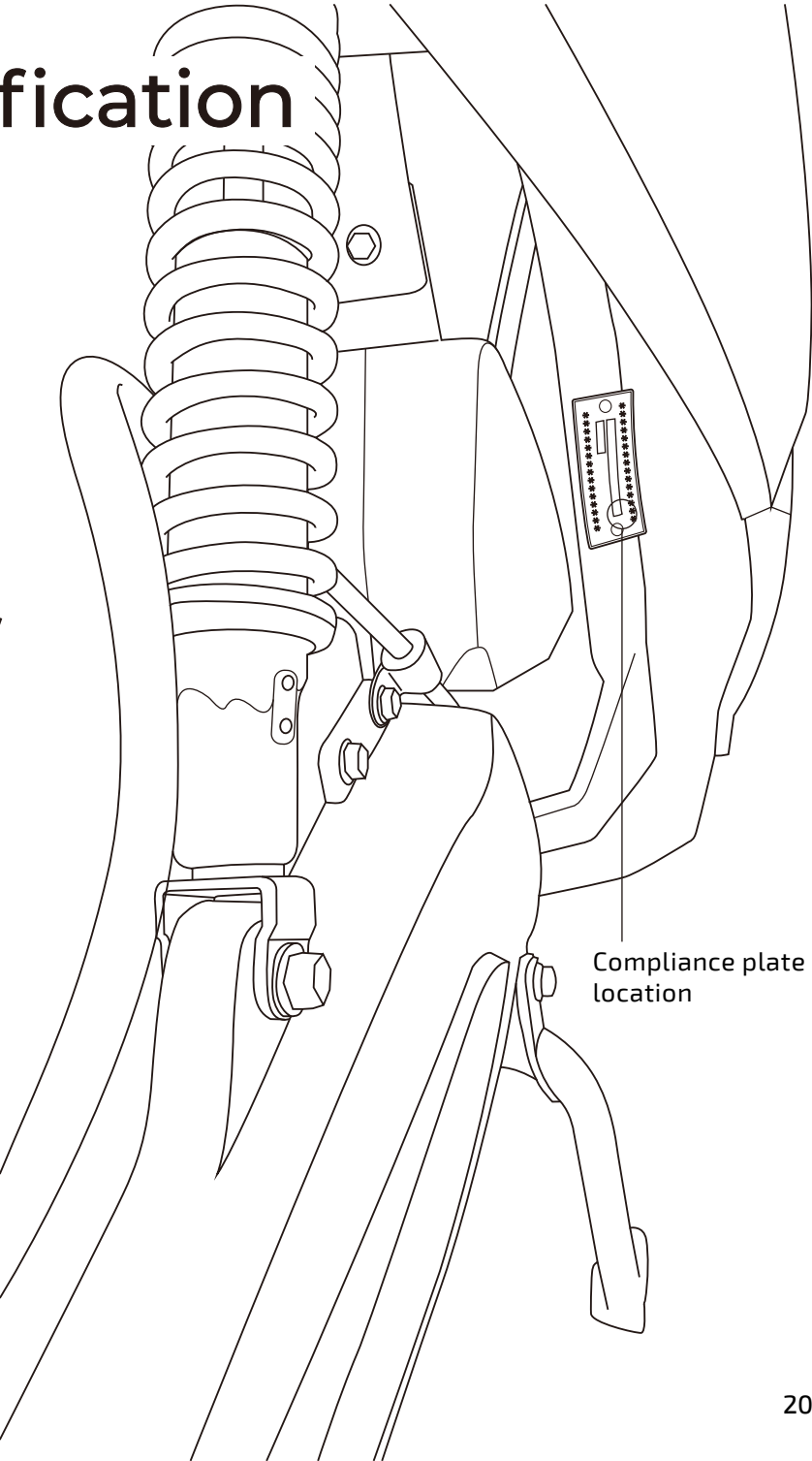
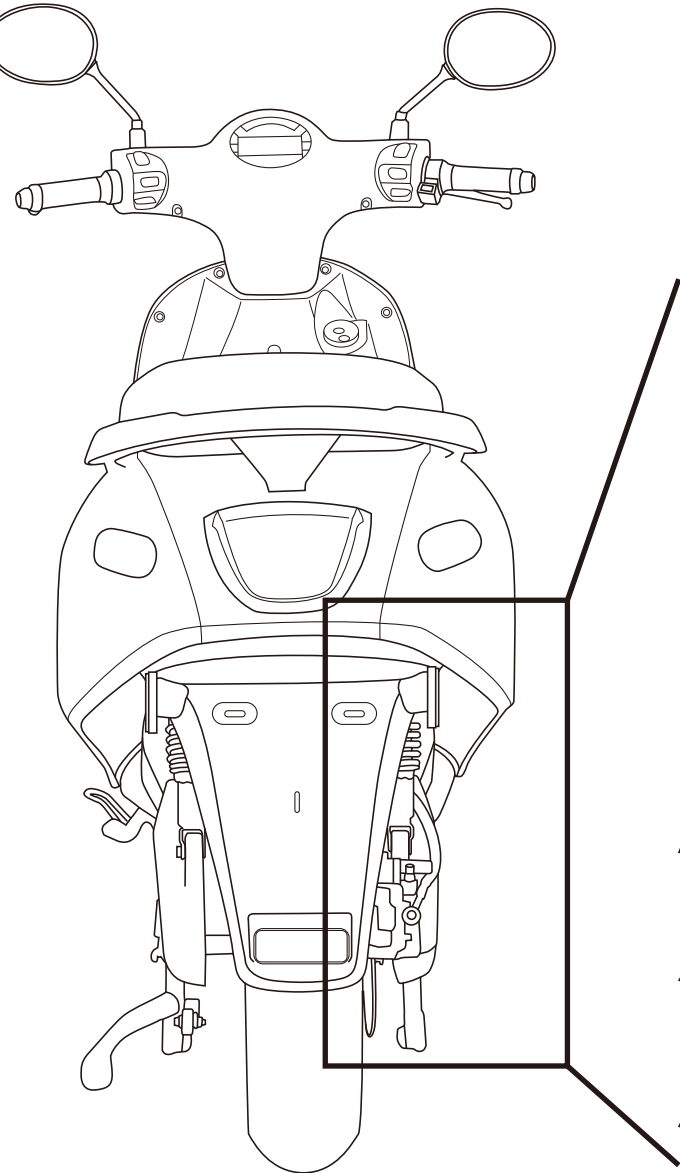

Compliance plate location

Riding

Pre-Ride inspection

A pre-ride inspection will only take a few minutes, and should be conducted every day before you ride your Arthur.

1. PowerPack – ensure the PowerPack is correctly fitted, and cables correctly attached.
Check charge level
2. Brakes – check for correct operation; make sure there is no fluid leakage
3. Tyres – check condition and pressure
4. Lights and Indicators – check for correct operation
5. Throttle – check for correct and smooth operation

Contact an authorised Fonzarelli representative if you identify an issue.



Warning! If the pre-ride inspection is not conducted before using the Fonzarelli, damage to equipment or severe injury could result.

Starting procedure

1. Insert the key and turn clockwise to the ON position
2. Mount the scooter, and move side-stand to stowed position
3. Ensure the kill-switch is in the RUN position
4. Ensure the kick stand is UP and all warning lights are extinguished
5. Your scooter is now ready to ride

Riding

Review safety before you ride

After completing the procedure, Arthur is ready to ride.

1. Slowly and smoothly open the throttle to accelerate
2. Close throttle to coast; momentum will continue to carry you forward

Braking

1. For slow braking under normal conditions, close throttle and smoothly apply pressure to both front and rear brake control levers
2. For maximum braking, close throttle and apply firm pressure to both front and rear brake control levers

Ensure that you shift your body weight to a stable position and brace against the force of deceleration to maintain control of the scooter.

Arthur CBS

Arthur CBS (combined braking system) assists brake control by linking the front and rear hydraulic disc brakes. In this system, the rider's action of depressing one of the brake levers applies both front and rear brakes.

Always brake before entering a turn, as firm application of brakes mid-turn may result in loss of control. When braking in wet conditions or on loose surfaces, braking manoeuvres should be smooth, as sudden application of brakes may result in loss of control.

Riding Functions

Reverse Mode

1. After coming to a complete stop, **hold down** the BLACK reverse button. Note this button is also 'Ready' mode, used to start the vehicle.
2. While holding reverse, slowly open the throttle
3. The scooter will travel in reverse at a slow pace

Engage the brake levers to turn off reverse mode

NOTE: Reverse will only engage after brake has been applied

Regenerative braking

Regenerative braking is engaged automatically when braking applied, improving efficiency by returning energy to the PowerPack that would otherwise be wasted.

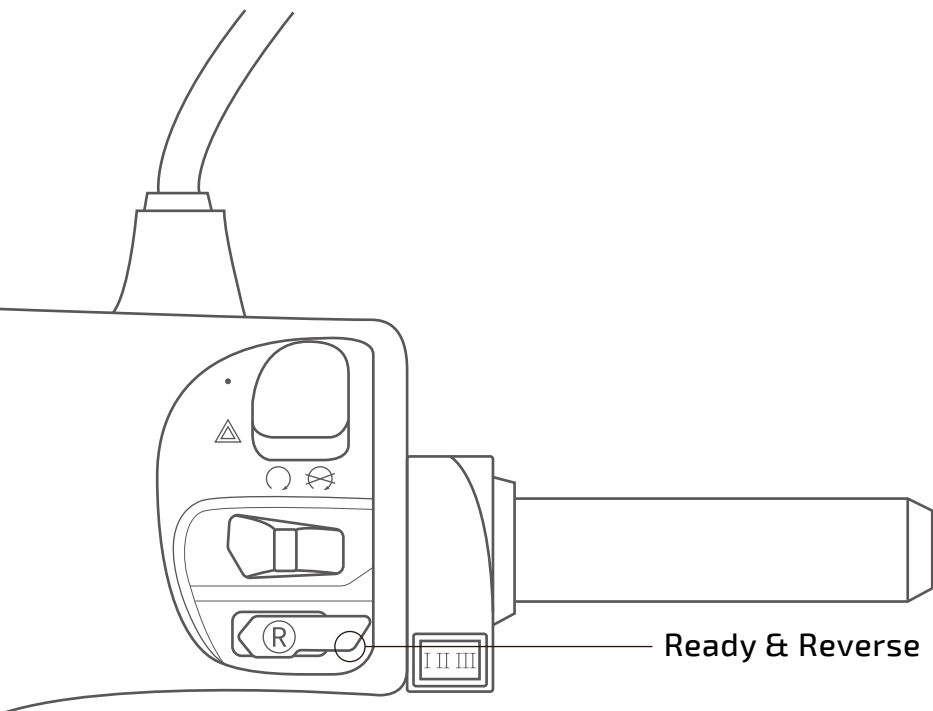

Storage & Load

Combined weight of rider, passenger, accessories and cargo must never exceed the maximum rated load capacity of 150kg

To improve stability when carrying cargo, try to position much of the weight low near the scooter's centre of gravity

Never attach heavy items directly to the scooter's handlebars, as handling and steering response may be impeded.

All models have a lockable Glovebox

Arthur 1 and Arthur 2 models have under saddle storage of 20L. Arthur 3 has limited under saddle storage of 4L.

TIP

 Weight distribution is an important factor in the stability and control of the vehicle.

Take care when adding accessories or cargo, as this can affect the performance of the vehicle.

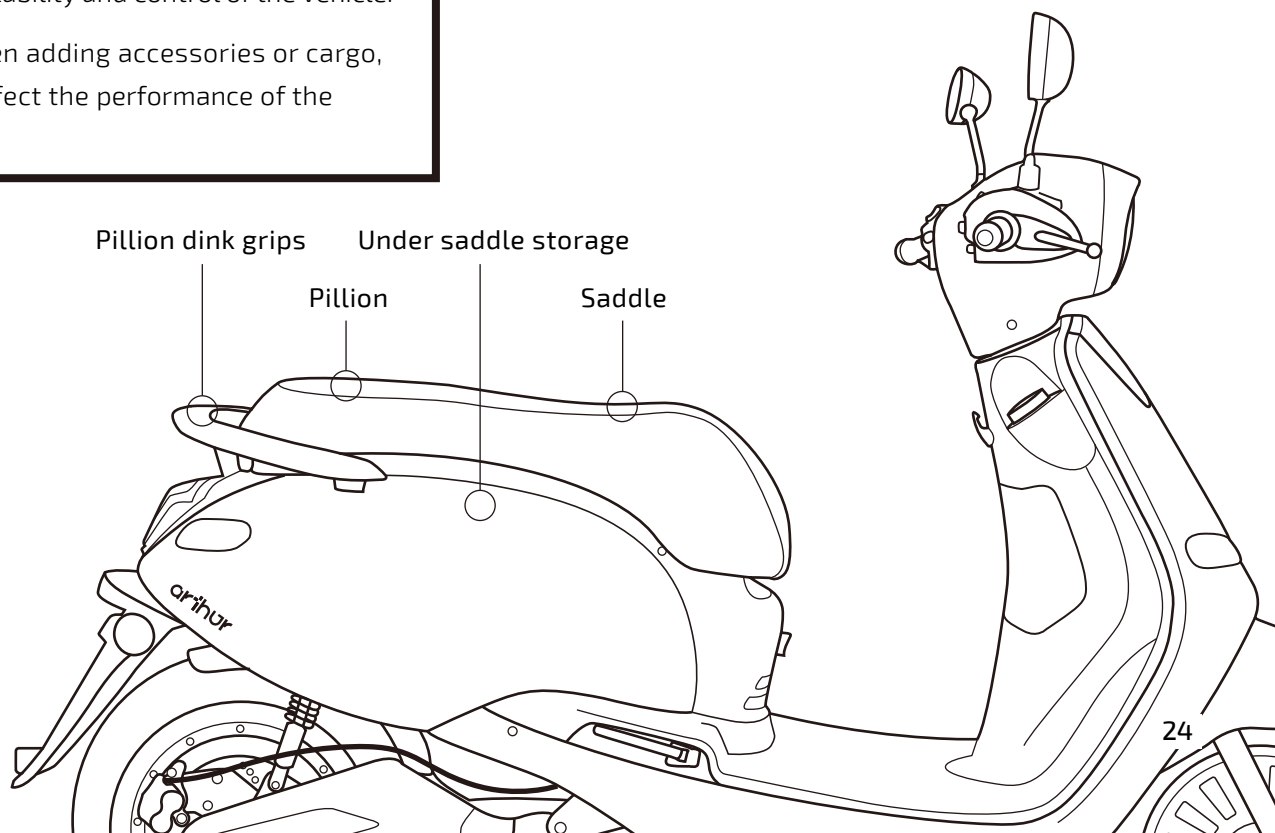

Storage & Load

Pillion passenger

Arthur is licensed to seat one operator and one pillion passenger

Range will be impacted when carrying a pillion passenger, due to additional load

Ensure that the pillion passenger:

- Holds the pillion passenger grips
- Places feet on pillion foot pegs
- Leans into corners with the operator

Accessories

All genuine Fonzarelli accessories are designed and tested to ensure that each is fit for use.

Fonzarelli Bikes cannot be held liable for incompatibility, or damages incurred by the use of non-Fonzarelli accessories.

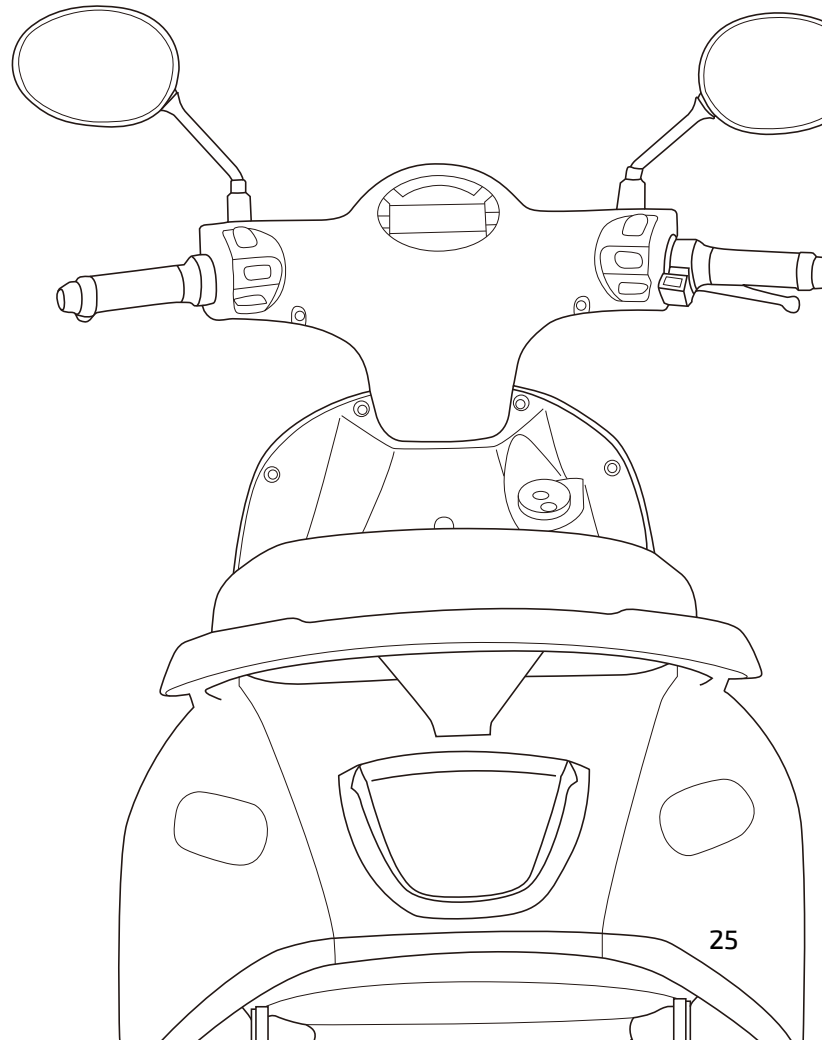

NOTES



In many states whereby Arthur 1 can be operated under a driver licence, the operator cannot carry a pillion. Laws vary by region. Be sure to check with your local state on pillion passenger rules.

Specifications

arthur	Model 1	Model 2	Model 3
SPEED	50 KM/H	65 KM/H	80 KM/H
MAX^	X	✓	✓
RANGE	50 KMS	50 KMS	100 KMS
POWER	3 kW	5.5 kW	8 kW
CHARGING	Portable	Portable	Bike to wall socket**
BRAKES	Hydraulic disc brakes, Front + Rear, CBS/EBS (combined and electric braking system)		
FEATURING	Stylish LCD Dash, LED headlamp, Regenerative Braking, Reverse mode, Carbon Structural Frame, Quick storage compartments, 12 inch wheels and more		

Maintenance

Cleaning

To maintain appearance, and prevent paint and corrosion damage to the vehicle, regularly:

1. Wash with a diluted solution of car wash soap
2. Remove PowerPack when washing vehicle
3. Dry with a microfibre cloth
4. Polish with a wax based spray protectant, and buff with a microfibre cloth



Warning! Do not allow water to enter PowerPack compartment. If cleaning PowerPack, attach terminal covers, and wipe with a damp cloth.

Do not use hydrocarbon based cleaning products, as paint damage may result.

Tyres

Standard tyres for the Fonzarelli are 12 inch tubeless.

Inflation pressure should be checked on cold tyres 20°C periodically.

Correct pressure is 32PSI Front, 34PSI Rear. Riding with a pillion or heavy load we recommend 33PSI front, 36PSI rear.



Warning! Improper inflation will lead to premature wear of tyres, and can cause reduction of stability, traction and range.

TIP

Regularly rinse chrome, stainless and aluminium components with fresh water, particularly if you live in coastal areas. If surface rust appears, clean immediately with rust remover. Wipe switches with damp cloth.

Maintenance

Brakes

The Arthur has front and rear hydraulic disc brakes with CBS.

Brake system must be inspected during service to ensure there are no fluid leaks.

If brake control lever free play becomes excessive, and brake pads are not worn, air may have entered the hydraulic lines, and the hydraulic lines must be bled. See an authorised repairer.



Warning! Brake fluid is corrosive, and may cause irritation. Avoid contact with skin or eyes.

In case of contact, flush thoroughly with clean water and seek medical attention if contact with eyes.

How to check and replace brake fluid.

An authorised repairer must replace the brake fluid.

Service Schedule

Item	Routine	Every Ride	Mini-Service	Service Schedule is calculated by kilometres run or by time in months since previous service (whichever occurs first).				
			1,000 kms or 1 month	2,500 kms or 6 months	5,000 kms or 12 months	10,000 kms or 12 months	15,000 kms or 12 months	
Brake Fluid (front & rear)	Check brake fluid level.	✓	✓	✓	✓	✓	✓	✓
	Replace brake fluid (every 24 months).					Every 24 months		
Front & Rear Brake Lever Pivot Shaft	Check operation and for fluid leakage. Replace brake pads if necessary.	✓	✓	✓	✓	✓	✓	✓
	Apply silicon grease lightly. Check operation and for oil leakage. Service as necessary.		✓	✓	✓	✓	✓	✓
Wheels	Check run-out, and for damage. Replace if necessary.			✓	✓	✓	✓	✓
Tyres	Check air pressure at 20°C <small>XI FR 28PSI, RR 32PSI Arthur FR 32PSI, RR 32PSI NKD FR 32PSI, RR32PSI</small> Correct if necessary	✓	✓	✓	✓	✓	✓	✓
	Check tread depth. Replace if necessary.			✓	✓	✓	✓	✓
Fasteners	Check all fasteners, bearings and fittings operation. Refer to torque adjustment chart. Replace / adjust if necessary.		✓	✓	✓	✓	✓	✓
Front & Rear Shock Absorber Assembly	Check operation and for oil leakage.	✓		✓	✓	✓	✓	✓
Throttle Grip	Check operation and adjust if necessary.	✓		✓	✓	✓	✓	✓
Ignition/Saddle Locks	Check operation. Apply grease on pivot. Replace if necessary.			✓	✓	✓	✓	✓
Power connector	Check operation and adjust / lubricate with non-conductive lubricant as necessary.	AS REQUIRED						

You can select to carry out the one month mini-service or 6 month service. If you choose the mini service the first scheduled service will be 12 months later.

Electronics

PowerPack storage

Storing the PowerPack for extended periods (i.e.; longer than two months) can result in minimal loss of capacity (maximum 1-2%), storing the PowerPack in ideal conditions will obtain optimum safety and minimise the affect of capacity loss:

1. Store the PowerPack in a cool, dry place ~15°C
2. Charge the PowerPack to 80% before storage
3. Periodically check PowerPack charge level and charge back to 80% (every few months)

Warning! Storing Lithium Ion cells at 0% SOC for extended periods of time will result in destruction of the PowerPack due to internal shorting.

Operating temperature

0 to 45°C

Warning! If air temperature is 38°C or above and/or high humidity, allow the system to rest for up to three hours prior to charging.

Charge intervals

While the battery cells in your PowerPack will not be affected due to charge memory, from time to time you should discharge your PowerPack to calibrate with the cell management system.

Weather

During extremely hot temperature, after riding, allow 1 to 2 hours.

Storage

Store PowerPack at 80%.

Long-term storage

If the PowerPack is kept stored for a long time (3 months or more), it is strongly recommended that the cell is preserved at dry and low-temperature.

If you do not ride for an extended time (i.e. such as during winter) we recommend to repeat the Power-Pack running in procedure for 2-3 cycles. The Power-pack optimal storage between 60 to 80%.

Warning! The Powerpack must not be stored below 60% for long term storage. Never leave the Powerpack discharged <10%.

Any problems caused by malfunction of the PowerPack due to unsuitable use and care of PowerPack is not covered under warranty. The handling conditions described above must be followed or warranty will be voided.

Range & Performance

Your range results are a direct reflection of your riding habits. The more conservatively you ride, the better range you can expect from your Arthur scooter.

Key factors that will affect range include speed, acceleration, number of starts / stops, load weight, air temperature and terrain.

Ride conservatively when you first get your Arthur and adjust your riding style to reflect what you want out of your ride.

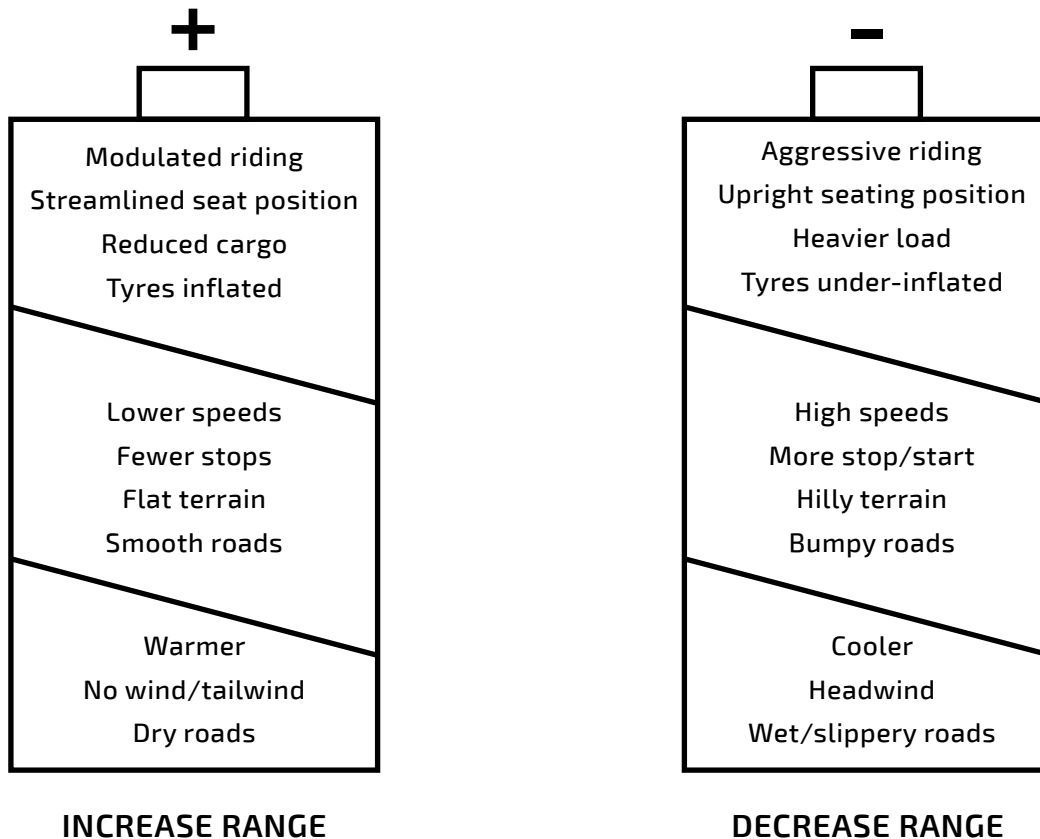

Warranty

Product Warranty, Returns and Legal

Arthur has been subject to careful final checks and test rides before delivery to you.

Subject to the terms of the **ELECTRIC SCOOTER CO PTY LTD AUSTRALIAN WARRANTY**, ESCO will repair or replace any defects in the materials or workmanship of Arthur that are notified to ESCO during the warranty period as follows:

Major Components - a 24 month or 10,000 kilometre warranty on the Powerpack, controller, gauge and motor; and

General Components – a 12 month or 5,000 kilometre warranty on all other components of the vehicle.

See the terms and conditions of the Product Warranty, Returns in the **FONZARELLI ELECTRIC MOTO SCOOTER LIMITED AUSTRALIAN WARRANTY** document at fonzarelli.co/warranty

Disclaimer

All information in this publication is based on the latest production information available at the time of the last version release. ESCO reserves the right to make changes at any time without notice.



fanzarelli

ELECTRIC MOTO 